

Datasheet

# Agnostic Force Sensor

NDS11C – Strain gauge and temperature sensor  
V0.9 (Preliminary)

## FEATURES

- High sensitivity / high linearity
- Includes additional sensor for temperature compensation
- Low power consumption
- High durability
- Small footprint – TSLP housing
- SMD solderable
- Very small size

## TYPICAL APPLICATION

- Input systems with minimal deformation of the surface
- Force sensing applications

## DESCRIPTION

The NDS11C sensor is a piezo-resistive sensor offering low profile, low power consumption, high sensitivity and high durability. The NDS11C sensor is produced as a SMD type device with solder pads.

When the NDS11C sensor it is deformed, the internal resistance value changes, and the change in resistance can be detected as an analog voltage change through a Wheatstone bridge.

NDS11C also integrates a temperature sensitive Wheatstone bridge. This temperature signal output can be used as a compensation to reduce the influence of environmental temperature change on the force output signal.

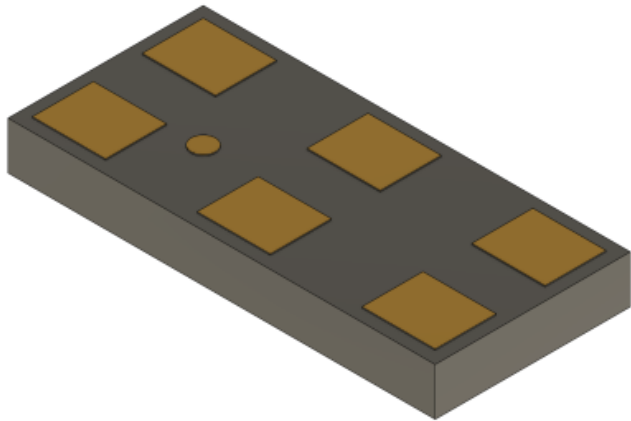

## ORDERING INFORMATION

Order Number	Part	Size	Packaging	MOQ
xxxxxx	NDS11C	3.5 * 1.6 * 0.4 mm	Tape & Reel	1000
xxxxxx	NDS11C	3.5 * 1.6 * 0.4 mm	Tape	100

## TABLE OF CONTENTS

	Page
FEATURES	1
TYPICAL APPLICATION	1
DESCRIPTION	1
ORDERING INFORMATION	1
PRODUCT DIMENSIONS	2
PIN CONFIGURATION & FUNCTION	2
ABSOLUTE MAXIMUM RATINGS	2
ELECTRICAL CHARACTERISTICS	2
CURVATURE RANGE & SENSITIVITY	3
SMT-FOOTPRINT & LAYOUT INSTRUCTION	3
SOLDERING PROFILE	3
PACKAGE INFORMATION	4
MOISTURE SENSITIVE LEVEL (MSL)	4
COMPLIANCE INFORMATION	4
REVISION HISTORY	4

PRODUCT DIMENSIONS

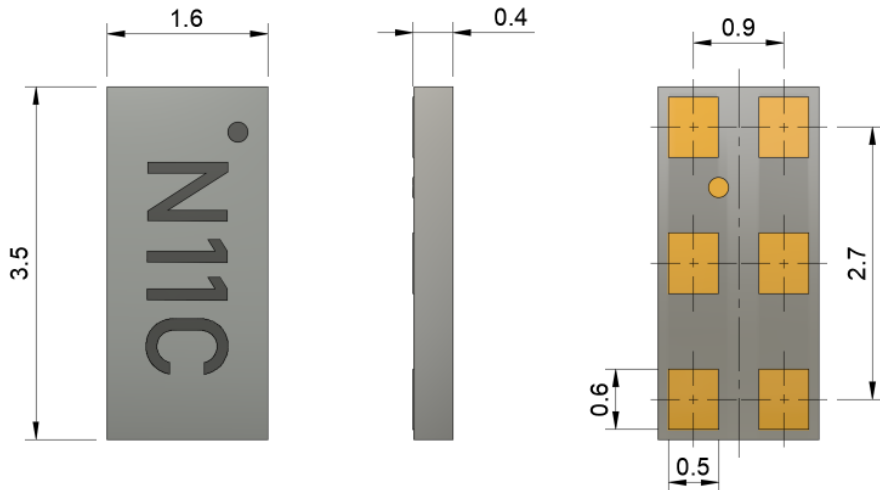

PIN CONFIGURATION & FUNCTION

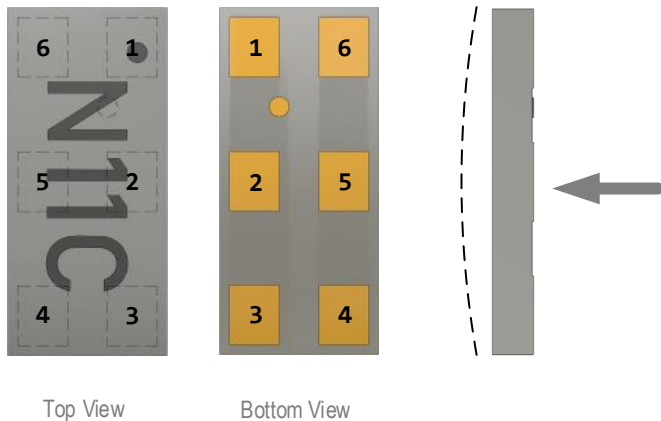

Pin	Pin name	Pin description
1	VCC	Sensor supply voltage
2	PWE	Power Enable
3	S-	Sensor negative output terminal
4	GND	Ground
5	MODE	Output mode – force (low or float) / temperature (high)
6	S+	Sensor positive output terminal

If MODE is floating or low, a small bending of NDS11C will result in a differential output signal – proportional to the applied force.

If MODE is high, the differential output signal is proportional to the temperature of the sensor. This value can be used to compensate the temperature drift.

ABSOLUTE MAXIMUM RATINGS

Parameter	Unit	Min	Max
Supply voltage	V		5
Storage temperature	°C	-25	80
Operating temperature	°C	-20	60
Curvature	m <sup>-1</sup>		5

ELECTRICAL CHARACTERISTICS

Parameter	Condition	Unit	Min	Typ	Max
Supply Voltage		V	2.4	3.3	5.0
Force Offset	@ 3Vdc	mV	-180		180
Force Sensitivity	@ 3Vdc	mV/m <sup>-1</sup>		35	
Force Temp. coefficient	@ 3Vdc	ppm/K			3000
Force Curvature Range		m <sup>-1</sup>			1.1
Force Bridge resistance		kOhm	8	10	12
Force signal drift	@ 3Vdc	ppm/K		200	
Temperature Offset	@ 3Vdc	mV	-350	-50	-50
Temperature Sensitivity	@ 3Vdc	mV/K	15	20	25
Temp Bridge resistance		kOhm	10	14	18

## CURVATURE RANGE & SENSITIVITY

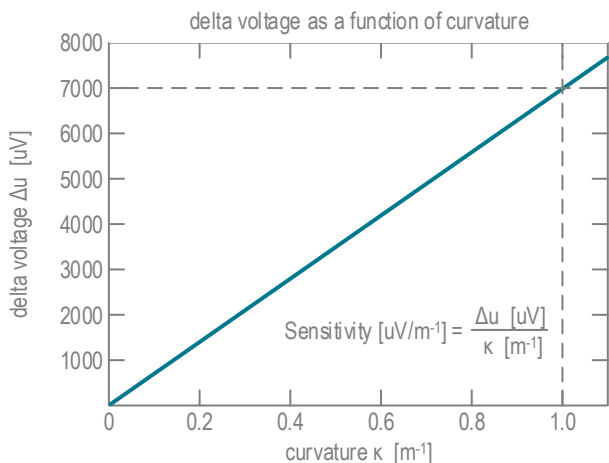

Curvature is defined as the change in direction as the curve is traversed. The curvature of a straight line is zero everywhere because its direction remains the same. A circle of radius  $r$  has the same curvature everywhere. The smaller the radius, the greater the curvature. For a circle:

$$\text{curvature } \kappa \text{ [m}^{-1}\text{]} = \frac{1}{\text{radius [m]}}$$

The characteristic range for the sensor is 0 to 1.1  $\text{m}^{-1}$ . This results in a bending radius of infinite to 0.9m.

## SMT-FOOTPRINT & LAYOUT INSTRUCTION

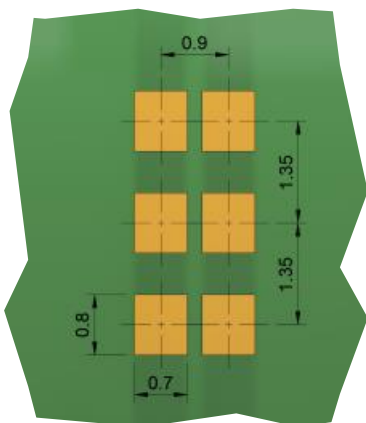

- Recommendation:
- Solder paste mask: 0.2mm (8mil) smaller than footprint
  - Solder mask expansion: 0.05mm (2mil)
  - Stencil thickness: 100um

## SOLDERING PROFILE & PLACEMENT INSTRUCTION

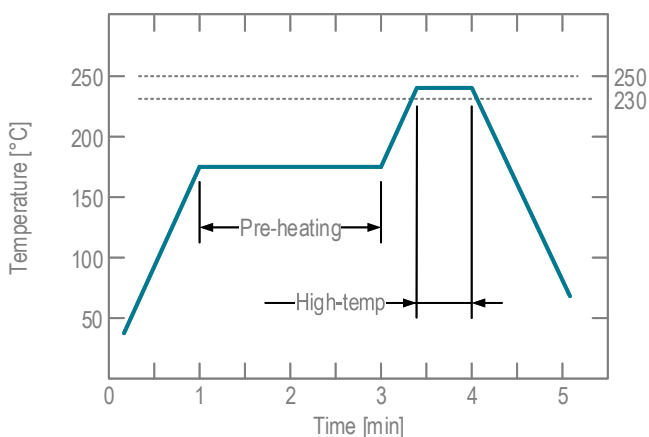

Pre-heating period	≥ 60s
Pre-heating temperature	<180°C
High-temperature period	30 to max 60s
Maximum soldering temperature	250°C

SMD Placement:  
 Placement force at SMD assembly: 1.5N with a soft nozzle (Max 2N)

**PACKAGE INFORMATION**

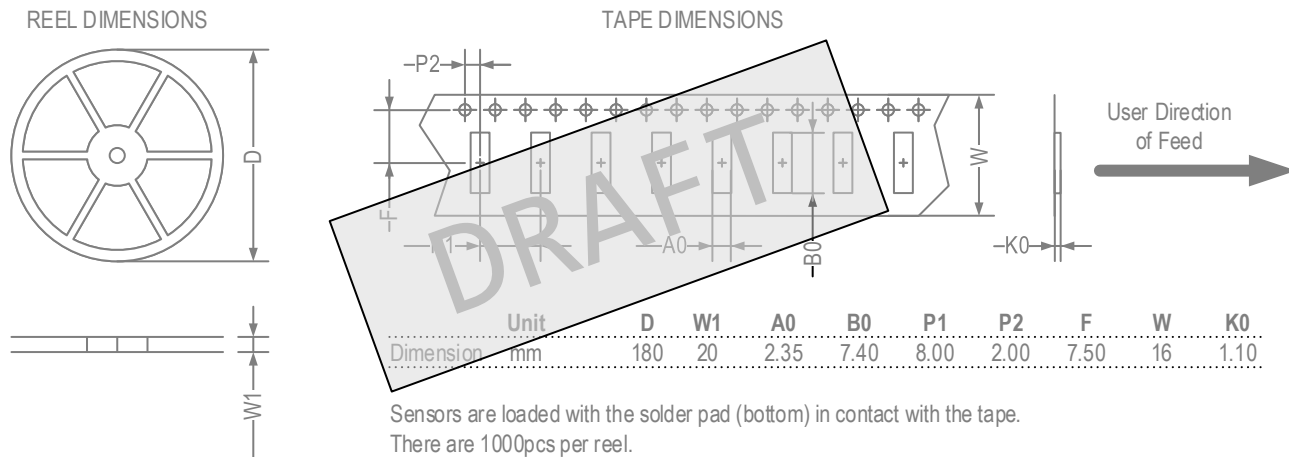

**MOISTURE SENSITIVE LEVEL (MSL) & ESD RATING**

The Moisture Sensitivity Level rating according to the JEDEC industry standard classifications is Level-2.  
The ESD protection (Human-body model - according to ANSI/JEDEC JS-001-2014) is ±4000V.

**COMPLIANCE INFORMATION**

The NDS11C sensor is in compliance with RoHS, REACH and CMRT. A written certification can be supplied upon request.

**REVISION HISTORY**

Version	Date	Description	Pages
V0.9	xxxx-xx-xx	Preliminary version	-